

# Control and Implementation of Solar Photovoltaic-Fuel Cell with Dual Ultra Capacitor Hybrid System

**<sup>1</sup>B.Dhivya, <sup>2</sup>D.Santhosh Kumar**

<sup>1</sup>PG Scholar, Dept. of Electrical and Electronics Engineering, Vivekanandha Institute of Engineering and Technology for Women, Tiruchengode, District Namakkal

<sup>2</sup>Assistant Professor, Dept. of Electrical and Electronics Engineering, Vivekanandha Institute of Engineering and Technology for Women, Tiruchengode, District Namakkal

## Abstract

*This project presents a hybrid system comprise of Photovoltaic (PV), Battery, Ultra capacitor (UC), Fuel Cell (FC) to meet isolated DC load demand. The PV is the primary energy source, fuel cell is the auxiliary power source where as battery and Super capacitor both are considered for their different power density to supply transient and steady load respectively. Fuel cells are an attractive option because of high efficiency, modularity and fuel flexibility; however, one main weak point is their slow dynamics. The sources in this hybrid system complement each other very well against environmental variations and load variations. Of the many storage systems the use of ultra capacitor gives advantage of absorbing and contributing to power transients quickly and efficiently. To increase the reliability of the system source Fuel cell has been chosen to keep the battery fully charged. The battery sources are connected to DC bus by DC-DC converters. A power flow control strategy adapts their variable DC voltage to Bus voltage by means of these converters. In this work, Fuel cell is chosen to work for a limited period. This will avoid the over sizing of the Fuel cell and limit the operational cost of the system. In this paper, the structure of the hybrid power system is described, and control strategies for power management of the hybrid power system are discussed. The proposed hybrid power system is then verified by numerical simulation. The whole energy management principle has been validated in MATLAB/SIMUINK with variable load demand and solar radiation profile.*

## Keywords

*Photovoltaic Cells, Fuel Cells, Battery, Ultra Capacitor, MPPT, Hybrid System, Four Leg Voltage Source Converter*

## I. Introduction

At present the power demand is mainly met by the energy from conventional fossil fuels which will be depleted after few years. There is a necessity to conserve the fossil fuel resources for further uses because of increasing energy demand. Due to increased green house gas emissions from the power plants and industries that make use of fossil fuels, the climatic conditions are worsened. This necessitates the use of renewable or alternate energy sources to meet the increasing power demand which are known to cause less pollution. Photovoltaic (PV) cells are semiconductor p-n junction devices produce DC power directly using energy from sunlight. The PV power system operates without noise and requires no maintenance as compared to other renewable energy sources. Since the solar irradiation on earth is intermittent, hybridizing PV system with other source is necessary to provide continuous and reliable supply of electricity. Fuel cells (FC) supply constant DC power by converting chemical energy to electrical energy. Wind energy has complementary profiles with solar energy but it can be effectively extracted only in the regions where enough wind is available and its installation cost is high. Battery as a storage device is less reliable if used with solar energy systems. Hence the fuel cell is the alternative source for backup when the standalone residential loads are considered. As long as the fuel (hydrogen and oxygen) is available, fuel cell keeps generating DC electricity with an efficiency of about 60%.

A stand alone system consisting of fuel cell as the major energy source and super capacitor as the storage device. The DC-DC converters are not used at the source side in this proposed system. The voltage and phase angle control strategy is used to control the inverter operation. The super capacitor bank can successfully compensate for load and source side variations and transients as it has a high power density. The load tracking was done using sensors and fuel rate control within the fuel cell model. In this

project, the photovoltaic array and fuel cell system were hybridized along with super capacitor to provide continuous power supply. The comparison made between the different types of fuel cells shows that the proton exchange membrane fuel cell (PEMFC) is appropriate for standalone applications and power levels considered. A complex control structure for the same hybrid system is proposed in which additional power was stored in ultra capacitor and hydrogen electrolyzer and excess power is given to variable dump load.

Many researchers have compared the maximum power point tracking (MPPT) techniques for photovoltaic systems and found that incremental conductance algorithm is accurate and efficient. The inverter output voltage consists of harmonics. The filters are necessary to achieve a sinusoidal output voltage. In a standalone system when the load power suddenly changes, the voltage at the source falls and frequency will be disturbed. Hence a control strategy has to be developed to regulate voltage and frequency of the system so as to maintain the system stable and safe. The different techniques are reported to manage the power in a hybrid system. In this work, the hybrid system uses PV array and fuel cell along with super capacitor bank to supply or absorb load transients. In this isolated hybrid system, the super capacitor bank is directly connected to the DC bus. This work aims to develop simpler control strategies for power management as compared to the existing literatures. The control system comprises of MPPT controller for PV system, controller for fuel cell system for power management and inverter controller to regulate voltage and frequency. Many researchers have focused their study on control of hybrid system of photovoltaic-super capacitor-battery based hybrid energy system and fuel cell-battery-super capacitor based hybrid energy system to supply hybrid vehicles type load. They have implemented flatness based control strategy and classical PI controller based control to study photovoltaic-fuel cell-super

capacitor hybrid energy system respectively. In this project hybrid photovoltaic-fuel cell-battery-super capacitor system has been chosen for the application of standalone DC load isolated from the utility grid. It can be a critical load located in remote areas, telecom load, ATM, hospital, military establishment etc. Battery and super capacitor both as the storage device make the system able to supply all type of loading condition. Whereas photovoltaic and fuel cell, being the main sources try to keep the storage devices charged to desired level. In this study, a new control strategy has been proposed for fuel cell system. Fuel cell is only used to charge battery when battery state of charge reaches below its specified minimum state of charge limit, which will reduce fuel usage by reducing fuel cell running period, thus reducing system operational cost.

**II. System Representation**

The hybrid power system comprises a PV panel, a fuel cell stack, a ultra capacitor, which are connected to the same DC voltage bus through appropriate dc-dc power converters and controls. Fig. 1 illustrates the structure of the proposed hybrid power system. There are two main sources of energy: PV panel and fuel cell stack. Although the battery is an energy storage device, it is also a source of energy when the load demands excess energy. The PV panel provides as much power as possible to the load. The function of the fuel cell is to supply to the load the rest of the average power that the PV panel cannot meet. Suitable power converters are used to connect the power sources to a common DC-bus. The currents and voltages are monitored continually and through proper power management subsystem power flow is monitored.

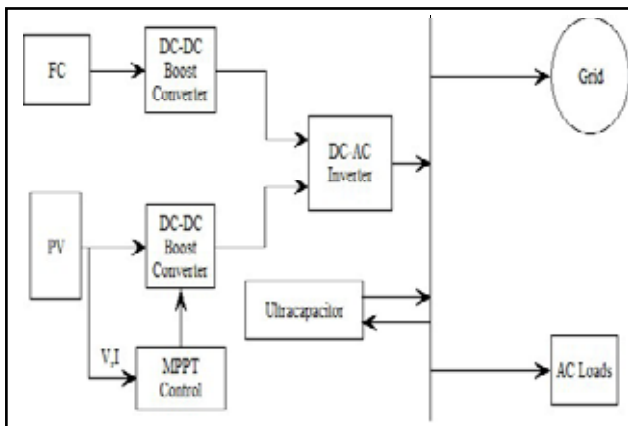

Fig.1 : Structure of the hybrid PV-fuel cell-ultracapacitor power system

Fig. 2 illustrates the circuit schematic of the PV power subsystem. The PV panel powers the load and charges the battery through a boost converter which acts as a maximum power point tracker. A diode D1 is used to prevent the current from flowing back to the PV panel since the reverse current might damage the panel. The boost converter is driven by a PWM generator and is controlled by a digital controller.

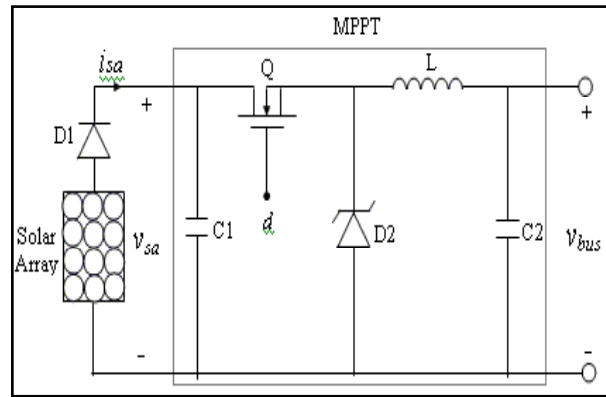

Fig. 2 : Circuit schematic of the photovoltaic power subsystem

A boost converter, as shown in Fig. 3, is selected to adapt the low DC voltage output from the fuel cell stack to the regulated bus voltage. The power stage of the fuel cell converter consists of a main switch S1, a Schottky diode D1, a high frequency inductor L1, and a filtering capacitor C1. A diode D0 is used to prevent the current from flowing back to the fuel cell stack since the reverse current might damage the stack. The boost converter is driven by a PWM generator. Due to the low current operation, MOSFET switches are chosen for the boost converter. Switch S2 is a shutdown device for security purpose in case that there is a short-circuit fault in the circuit or a device failure.

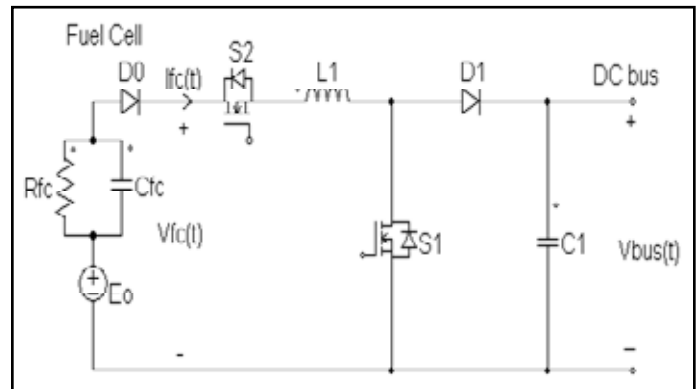

Fig. 3 : Circuit schematic of the fuel cell power subsystem.

The battery is directly connected to the voltage bus. The power may flow through the battery in both directions. The charging current is regulated by controlling the bus voltage. This is achieved eventually by regulating the PV source and the fuel cell source.

**III. PV SYSTEM MODEL, MPPT**

In PV system many cells are connected in series and parallel to provide the desired output terminal voltage and current. This PV system exhibits a nonlinear I-V characteristic and is modeled as a current source across a diode [6]-[8]. The parameters used in the mathematical modeling of the PV system and the governing equations are expressed as below.

$$I = I_{pv} - I_o [\exp(V + R_s I / V_t a) - 1] - V + R_s I / R_p \quad (1)$$

where,

- IPV is current due to incident light
- Io is reverse saturation current
- Vt thermal voltage of array
- a ideality factor
- Rs series resistance
- RP parallel resistance

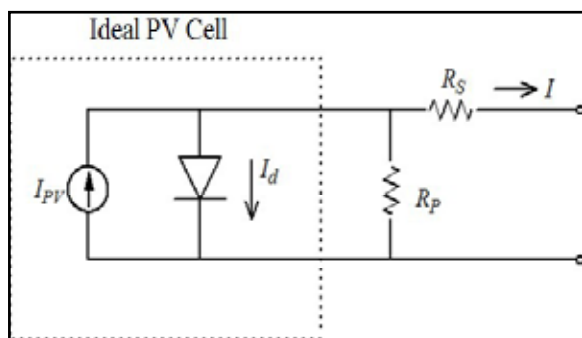

Fig.4 : Photovoltaic model

Since the solar insolation varies with time and other environmental factors the operating point of the PV should be adjusted to track maximum power.

**IV. DYNAMIC MODELING OF A PEMFC**

The relationship between the molar flow of any gas (hydrogen) through the valve and its partial pressure inside the channel can be expressed as,

$$q_{H2} / P_{H2} = k_{an} \sqrt{M_{H2}} - K_{H2} \quad (2)$$

Then, the net hydrogen flow can be written as sum of hydrogen input flow, hydrogen output flow and hydrogen flow during the reaction as,

$$\frac{d}{dx} P_{H2} = RT/V_{an} (q_{H2}^{in} - q_{H2}^{out} - q_{H2}^r) \quad (3)$$

According to the electrochemical relationship between the hydrogen flow and FC system current, the flow rate of reacted hydrogen is given by,

$$q_{H2}^r = N_0 I_{FC} / 2F = 2K_r I_{FC} \quad (4)$$

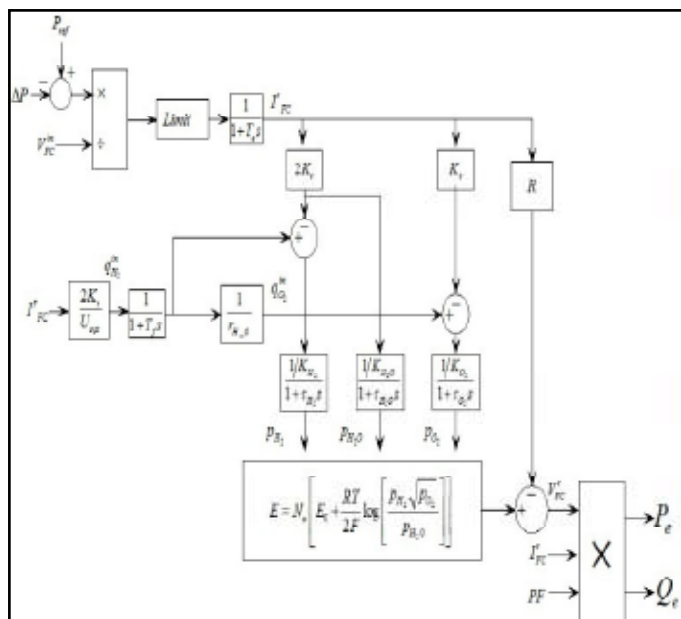

Fig.5 : Dynamic modeling of PEMFC

Using (2) and (4), and applying Laplace transform, the hydrogen partial pressure can be obtained as,

$$P_{H2} = 1/K_{H2} / (1 + \tau_{H2} s) (q_{H2}^{in} - 2k_r I_{FC}) \quad (5)$$

Same can be obtained for water and oxygen partial pressures. The

FC output voltage is the sum of Nernst instantaneous voltage and the ohmic voltage drop,

$$V_{cell} = E + \square_{ohmic} \quad (6)$$

Where,

$$E = N_0 [E_0 + RT/2F \log [P_{H2} \sqrt{P_{O2}} / P_{H2O}]] \quad (7)$$

**V. Ultracapacitor Modeling**

The classical equivalent circuit of a UC unit[11][12], consists of a capacitance (C), an equivalent series resistance (ESR, R) which represents the charging and discharging resistance and an equivalent parallel resistance (EPR, R) which models self discharging losses. The electrical equivalent diagram is given in Fig. 5.

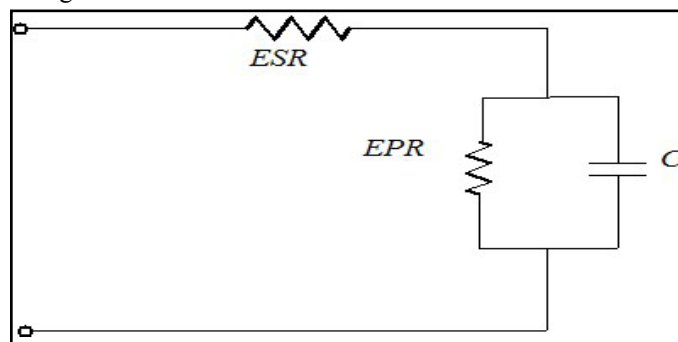

Fig.6 : Electrical equivalent of Ultra capacitor

**VI. Control Strategies For Power Electronic Converters**

**1. Photovoltaic MPPT Control**

PV power system makes use of MPPT controller to deliver the maximum power produced to the load all the time under varied insolation and temperature conditions. PV modules have relatively low conversion efficiency; hence MPPT controller is necessary for the solar PV systems. MPPT control is accomplished using DC-DC boost converter.

Among the MPPT techniques proposed in the literatures, the most widely used ones are incremental conductance algorithm (IC) and perturb and observe algorithm (P&O). Many researchers have implemented and compared both the algorithms and have found that implementation of P&O algorithm is simple. But, the output oscillates about the MPP and hence less efficient as compared to the incremental conductance algorithm [9, 10]. According to IC algorithm,  $dI/dV = -I/V$  at MPP as shown in Fig. 7. Also compared to than P&O method, this algorithm can track power rapidly for changing irradiance conditions with accuracy [10, 11]. This method considers the fact that the ratio of change in output conductance is equal to the negative of the output conductance at MPP. Fig. 8 shows the block diagram implementation of IC algorithm in MATLAB/Simulink.

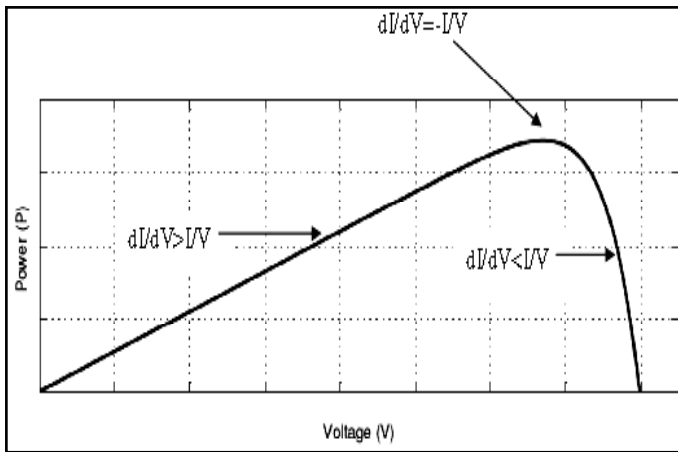

Fig. 7 : P-V curve of a PV cell

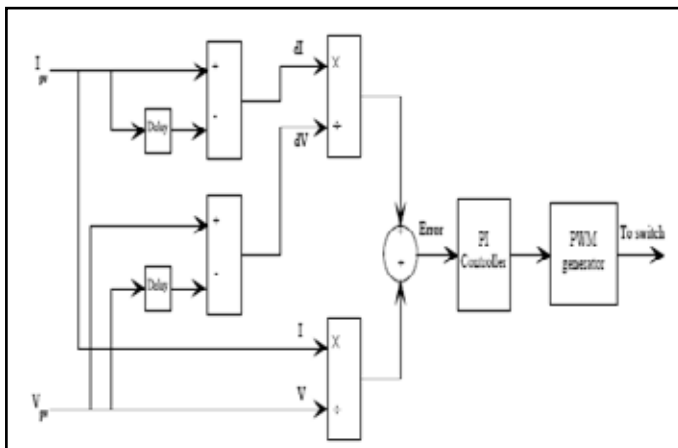

Fig.8 : Block diagram of IC algorithm in MATLAB/Simulink

**2. Current Control Strategy For Power Balance**

Solar energy being intermittent in nature, cannot meet the load demand alone. So when it is not able to supply the entire load demand, the additional power has to be supplied by the fuel cell system. The control strategy using current control technique for boost converter of fuel cell is shown in Fig. 8. The load current (RMS value) is taken as the reference and the total current generated from fuel cell and PV source is compared with the reference. The PI controller functions as current controller generating the duty cycle to compensate the mismatch in demand and generation. The PWM generator produces gate pulses depending on the duty cycle and the output power of fuel cell is controlled.

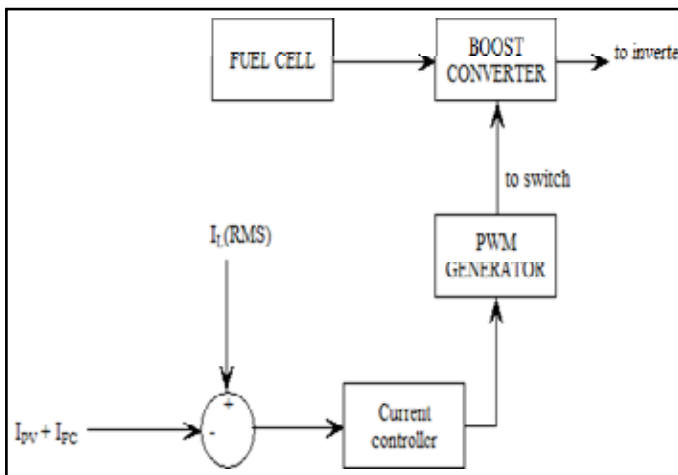

Fig. 9. Current control strategy for power balance

The sudden variations of load are common in stand-alone systems. In this paper, supercapacitor is used to supply or absorb transient power due to load variations. Supercapacitor is a device with high power density, small time constants and can absorb or supply high power within a short interval of time. Here supercapacitor bank is connected to the DC bus directly, as it can respond to transients without converter [2]. When the transients in the load appear, the supercapacitor supplies the power to match the load and to keep the system safe. When the PV power exceeds the load demand; supercapacitor absorbs the additional power from the PV system.

**VII. Conclusion**

This work presents an optimal energy management control strategy of PV-FC-Battery-SC hybrid system using PEM FC as auxiliary power source which will operate only for a small period. In FC, fuel cost is much higher compare to other sources running cost. It contributes a large amount in system cost value. Only by reducing the use and size, the annualized cost of FC system can be reduced. This criterion has been considered in the proposed energy management strategy. The main advantage of the proposed system is having less switching losses and reduces the harmonics. The simulation results show the reliability of power supply and reduced fuel usage. This control strategy can be extended to any type of DC load pattern. The simulation results shows that classical PI controller based control strategy for hybrid system not only supplies the load, but also keep battery and SC almost fully charged and reduces FC usage by reducing FC running period.

**References**

- [1] Z.Jiang "Power Management of Hybrid Photovoltaic-Fuel Cell Power System", *Proc. of IEEE Power Engineering Society General Meeting, Montreal Quebec, Canada 2006.*
- [2] A.Naik,R.Y.Udaykumar and V.Kole, "Power management of a hybrid PEMFC-PV and Ultra capacitor for standalone and grid connected applications",*Proc. of IEEE Int. Conf. Power Electron. Drives and Energy Sys.(PEDES),2012,pp. 1-5.*
- [3] M. Uzunoglu, M. S. Alam, "Dynamic Modeling, Design, and Simulation of a combined PEM Fuel Cell and Ultracapacitor System for Stand- Alone Residential Applications", *IEEE Transactions on Energy Conversion, Vol. 21, No. 3, pp. 767 – 775, 2006.*
- [4] N. Femia, " Optimization of Perturb and observe Maximum Power Point tracking Method," *IEEE Trans. Power Electronics, Vol. 20, pp. 963-973, July 2005.*
- [5] Z. Jiang, L. Gao, R. Dougal, "Flexible Multiobjective Control of Power Converter in Active Hybrid Fuel Cell/ Battery power Sources", *IEEE Transactions on Power Electronics, Vol. 20, No. 1, pp. 244-253, Jan 2005.*
- [6] M. Uzunoglu, M. S. Alam, "Dynamic Modeling, Design, and Simulation of a combined PEM Fuel Cell and Ultracapacitor System for Stand- Alone Residential Applications", *IEEE Transactions on Energy Conversion, Vol. 21, No. 3, pp. 767 – 775, 2006..*
- [7] Mangipudi Sreedevi, Carmel Tensy Pereira and Jyothi Bojjamma K., "Simulation Model of a Hybrid Photo Voltaic/Fuel Cell/ Ultra-Capacitor System for Stand Alone Applications", *International Journal of Engineering Research & Technology, Vol. 4, No. 06, 2015.*

- [8] *Guiting Xue, Yan Zhang and Dakang Zhu, "Synthetically Control of a Hybrid PV/FC/SC Power System for Stand-Alone Applications" Research Journal of Applied Sciences, Engineering and Technology, Vol. 5, No. 5, pp. 1796-1803.*
- [9] *Zineb Cabrane, Mohammed Ouassaid, Mohamed Maaroufi, "Integration of Supercapacitor in Photovoltaic Energy Storage: Modeling and Control", International Conference on Renewable and Sustainable Energy (IRSEC), 2014.*
- [10] *Samson, T. G., Underland, T. M., Ulleberg, Q., and Vie, P. J. S., "Optimal load sharing strategy in a hybrid power system based on PV/fuel cell/battery/super capacitor," Proceedings of the 2009 International Conference on Clean Electrical Power, pp. 141–146, Italy, 9–11 June 2009.*
- [11] *Jayalakshmi N. S. and Gaonkar, D. N., "Modeling and Performance Analysis of Grid Integrated Hybrid Wind and PV Based DG System with MPPT Controllers." International Journal of Distributed Energy Resources and Smart Grids, Technology and Science Publishers, Germany, 10(2), 2014, pp. 115-131.*